

NK 01



120
47"

NK 02



240
94"

NK 03

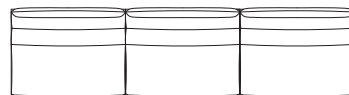

360
142"

1 ►

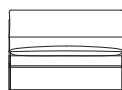
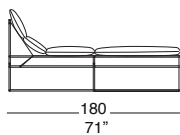

NK 04

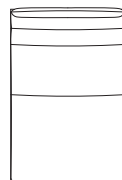

120
47"

180
71"

NK 05

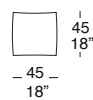

45
18"

N.B. Nelle composizioni, il tavolino è sempre previsto con il piano in vetro marmo

N.B. In the compositions the low table is always provided with the marble glass top.

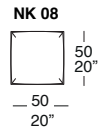
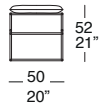
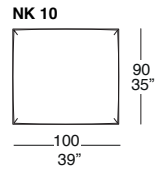
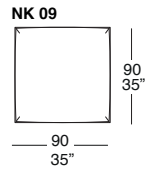
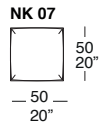
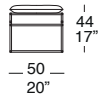

2 ►

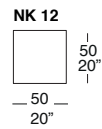
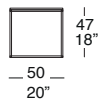
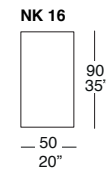
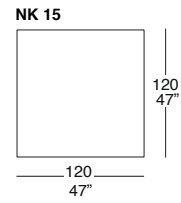
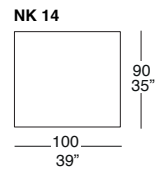
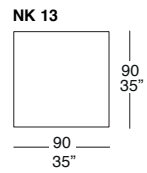
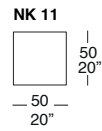
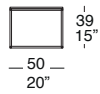

N.B. Nelle composizioni, il tavolino è sempre previsto con il piano in vetro marmo

N.B. In the compositions the low table is always provided with the marble glass top.

NK 17

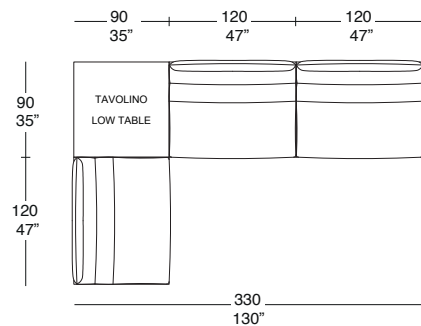

NK 18

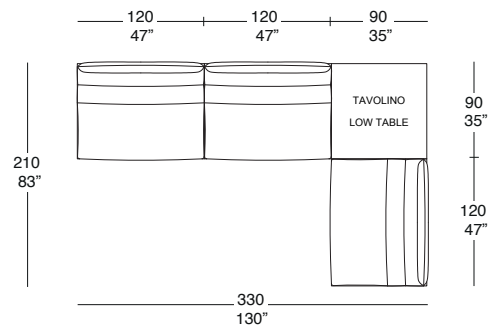

3 ▶

NK 19

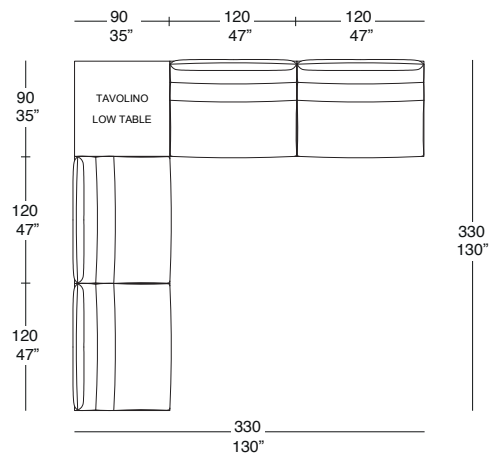

N.B. Nelle composizioni, il tavolino è sempre previsto con il piano in vetro marmo

N.B. In the compositions the low table is always provided with the marble glass top.

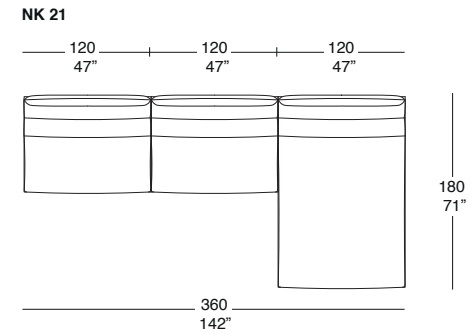
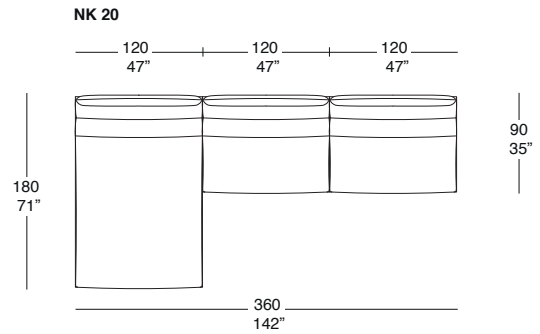

4 ▶

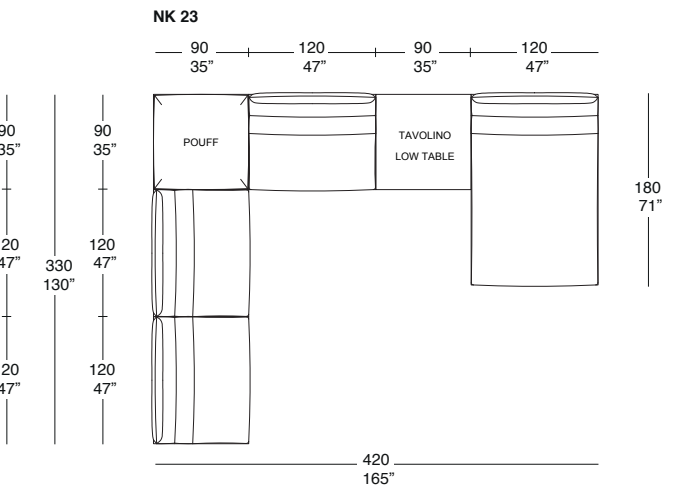
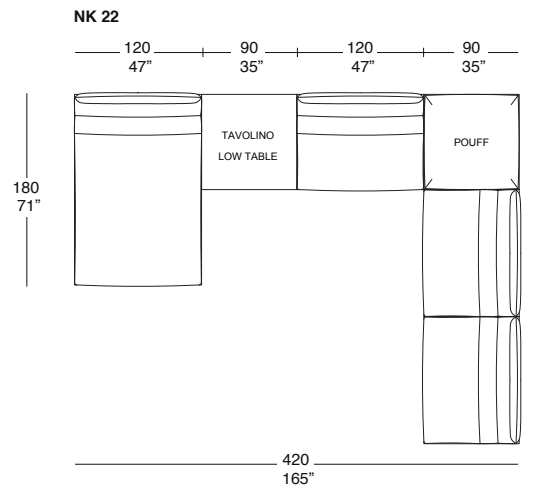

N.B. Nelle composizioni, il tavolino è sempre previsto con il piano in vetro marmo

N.B. In the compositions the low table is always provided with the marble glass top.

NK 24

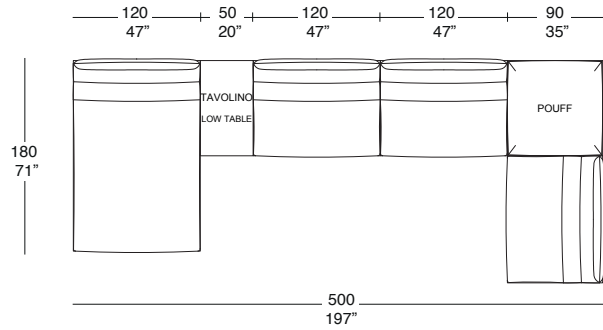

NK 25

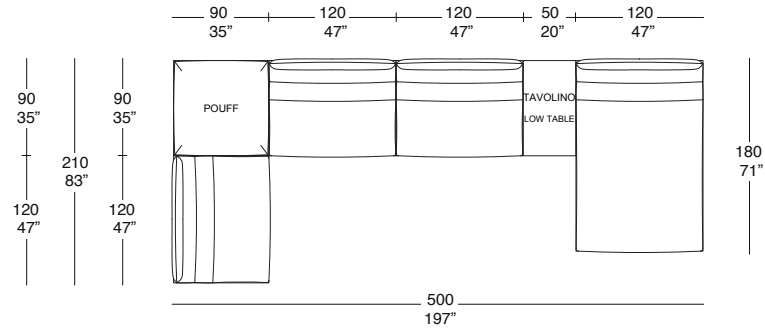

5 ▶

NK 26

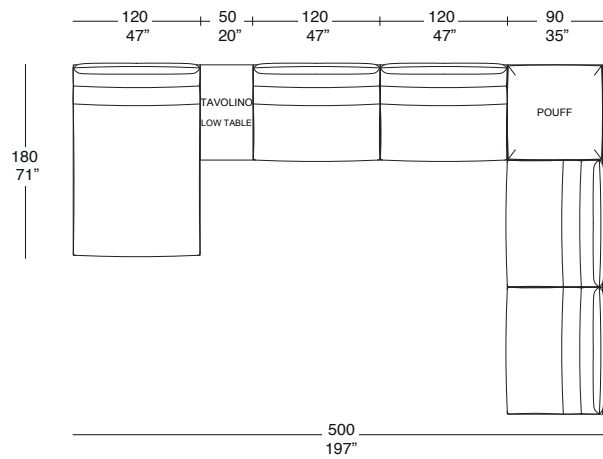

NK 27

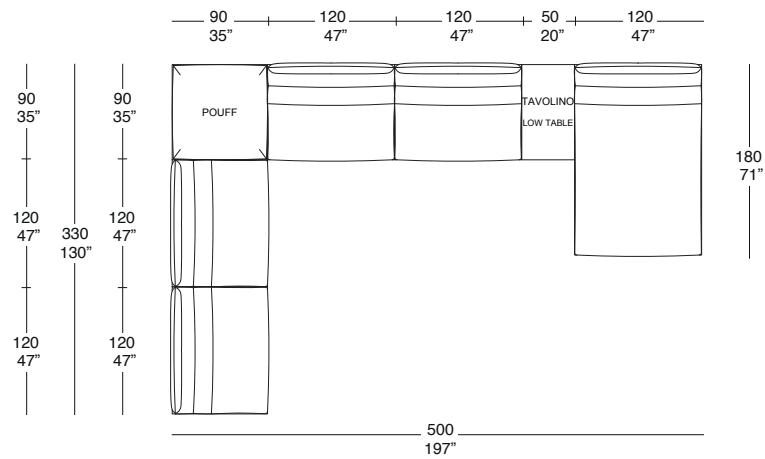

N.B. Nelle composizioni, il tavolino è sempre previsto con il piano in vetro marmo

N.B. In the compositions the low table is always provided with the marble glass top.